

Frontier® RADIOISOTOPE™



*Esco Frontier Radioisotope Fume Hood,
Model EFI-5UD4VW-8*

Radioisotope Fume Hood

Introduction

Esco Frontier Radioisotope Fume Hood is designed to be used when handling radioactive materials. This specialized fume hood is built with stainless steel internal surfaces (including the work surface) with coved seamless welded corners for easy cleaning and decontamination. Frontier Radioisotope fume hoods have been engineered to provide maximum safety while using low level Alpha and lower level Beta particles. In addition, these hoods provide containment performance similar to that of high performance low velocity fume hoods.

Superstructure

- Tri-wall construction for maximum robustness.
- Internal chamber constructed of stainless steel 304 with coved corners. Option to upgrade to stainless steel 316 is available.
- Chain and Sprocket Sash support system.
- Hood lighting is pre-wired. Lighting is electronically ballasted, energy efficient, instant start. Typical light intensity on work surface is > 1076 lux in zero ambient conditions.
- Reinforced work surface can hold loads of up to 15 kN/m² (2.175 lbf/in²).

Safety Features

- Shaping vanes increase airflow “sweep” at the critical area at the sidewall to improve containment, especially when laboratory personnel walk past in front of the hood.
- Sash stop limits sash movement beyond 457mm (18”), ‘encouraging’ user to work at safe positions.
- When sash is raised above 457mm (18”), it will automatically and gently fall back to the safe level (Esco’s creep-down mechanism) unless held in place. This allows the sash to be raised temporarily to the full open position for set up of equipment and apparatus in the hood, while enforcing regular operation

of the hood with lowered sash.

- The sash creep-down mechanism can only be disabled with a key. This permits the laboratory manager or safety officer to restrict operations at sash openings above 457mm (18.0”).
- Sash key lock allows the laboratory manager to restrict access to fume hood.
- The sash can also be locked down in the fully closed position with the key, in the event of a fume hood fault, facility shutdown, or, simply to restrict access to equipment set up in the hood.

Serviceability

- Stainless steel internal work zone allows for easy cleaning of all surfaces.
- Removable baffle system allows for thorough cleaning inside the hood.
- Chain and sprocket system requires minimal service.

Safety Certified and Tested

All Esco fume hoods are manufactured for the most demanding laboratory applications.

- Each Frontier Acid Digestion Fume Hood is tested to comply with ASHRAE 110:1995 and EN14175-3 standards.
- UL1805 Listed
- Sash is clearly labeled with operating instructions and illustrations.

Accessories and Options

- Esco offers a variety of options and accessories to meet application requirements.
- Additional services and electrical outlets.

- Base cabinetry is available for worktop requirements and additional storage area in the laboratory.

Warranty

The Frontier Radioisotope Fume Hood is warranted for 1 year excluding consumable parts and accessories. Contact your local sales representative for specific warranty details.



Gas and cold water fixture remote are positioned for easy access.

| Guide to Models | | | | | | | | | | | |
|-------------------------|-----------|----------------|----------|-------------------|----------|--------------|----------|------------|----------|-----------------------|----------|
| E F I - 4 U D 4 V W - 8 | | | | | | | | | | | |
| External Width | Code | Internal Depth | Code | Internal Liner | Code | Sash Type | Code | Color Code | Code | Electrical Code | Code |
| 1220 mm (48.0") | 4U | 900 mm (35.4") | D | SS 304 | 4 | Vertical | V | Esco White | W | 230V, AC, 50/60Hz | 8 |
| 1525 mm (60.0") | 5U | | | SS 316 (optional) | 6 | Combination* | C | | | 110-120V, AC, 50/60Hz | 9 |
| 1830 mm (72.0") | 6U | | | | | | | | | | |
| 2440 mm (96.0") | 8U | | | | | | | | | | |

* Combination Sash not available for EFI-8UD_ _W_ _ model.

| General Specifications, Frontier Radioisotope Fume Hoods | | | | | | |
|--|---|--|---|---|---|---|
| Model | EFI-4UD_ _W_ _ | | EFI-5UD_ _W_ _ | | EFI-6UD_ _W_ _ | |
| Nominal Size | 1.2 meters (4') | | 1.5 meters (5') | | 1.8 meters (6') | |
| External Dimensions * (W x D x H) | 1220 x 900 x 1725 mm 48.0" x 35.4" x 67.9" | | 1525 x 900 x 1725 mm 60.0" x 35.4" x 67.9" | | 1830 x 900 x 1725 mm 72.0" x 35.4" x 67.9" | |
| Internal Dimensions (W x D x H) | 996 x 672 x 1240 mm 39.2" x 26.5" x 48.8" | | 1301 x 672 x 1240 mm 51.2" x 26.5" x 48.8" | | 1606 x 672 x 1240 mm 63.2" x 26.5" x 48.8" | |
| Maximum Sash Opening | 740 mm (29.1") | | | | | |
| Exhaust Volume/ Static Pressure Required | Face Velocity | Sash Opening | | | | |
| | 0.3 m/s (60 fpm) | Design Opening: 457 mm (18.0") | 542 cmh @ 7 Pa 319 cfm @ 0.03" WG | 705 cmh @ 9 Pa 415 cfm @ 0.04" WG | 867 cmh @ 12 Pa 510 cfm @ 0.05" WG | 1192 cmh @ 8 Pa 702 cfm @ 0.03" WG |
| | 0.4 m/s (80 fpm) | Design Opening: 457 mm (18.0") | 723 cmh @ 13 Pa 425 cfm @ 0.05" WG | 939 cmh @ 17 Pa 553 cfm @ 0.07" WG | 1156 cmh @ 20 Pa 681 cfm @ 0.09" WG | 1590 cmh @ 14 Pa 936 cfm @ 0.06" WG |
| | 0.5 m/s (100 fpm) | Design Opening: 457 mm (18.0") | 903 cmh @ 20 Pa 532 cfm @ 0.09" WG | 1174 cmh @ 26 Pa 691 cfm @ 0.11" WG | 1445 cmh @ 28 Pa 851 cfm @ 0.12" WG | 1987 cmh @ 22 Pa 1170 cfm @ 0.09" WG |
| | 0.3 m/s (60 fpm) | Full Open: 736 mm (29.0") | 642 cmh @ 13 Pa 378 cfm @ 0.06" WG | 834 cmh @ 17 Pa 491 cfm @ 0.07" WG | 1027 cmh @ 22 Pa 605 cfm @ 0.09" WG | 1412 cmh @ 14 Pa 831 cfm @ 0.06" WG |
| | 0.4 m/s (80 fpm) | Full Open: 736 mm (29.0") | 856 cmh @ 23 Pa 504 cfm @ 0.10" WG | 1113 cmh @ 30 Pa 655 cfm @ 0.13" WG | 1369 cmh @ 39 Pa 806 cfm @ 0.17" WG | 1883 cmh @ 25 Pa 1108 cfm @ 0.11" WG |
| 0.5 m/s (100 fpm) | Full Open: 736 mm (29.0") | 1070 cmh @ 36 Pa 630 cfm @ 0.15" WG | 1391 cmh @ 47 Pa 819 cfm @ 0.20" WG | 1712 cmh @ 61 Pa 1008 cfm @ 0.26" WG | 2354 cmh @ 40 Pa 1385 cfm @ 0.17" WG | |
| Exhaust Outlet Diameter | 305 mm (12.0") | | | | | |
| Number of Exhaust Collars | 1 | | 1 | | 2 | |

* When sash is in full open position, total height of fume hood is 1725 mm (67.9"). Please ensure sufficient ceiling height clearance is available.

| General Specifications, Base Cabinet for Frontier Radioisotope Fume Hoods | | | | |
|---|---|---|---|---|
| Model * | EBA-4UDG-0 / EBA-4UDG-8 | EBA-5UDG-0 / EBA-5UDG-8 | EBA-6UDG-0 / EBA-6UDG-8 | EBA-8UDG-0 / EBA-8UDG-8 |
| Nominal Size | 1220 mm (24') | 1525 mm (60.0") | 1830 mm (72") | 2440 mm (96") |
| External Dimensions (W x D x H) | 1220 x 849 x 915 mm 48.0" x 33.4" x 36.0" | 1525 x 849 x 915 mm 60.0" x 33.4" x 36.0" | 1830 x 849 x 915 mm 72.0" x 33.4" x 36.0" | 2440 x 849 x 915 mm 96.0" x 33.4" x 36.0" |
| Net Weight | 76 kg (167 lbs) | 115 kg (253 lbs) | 140 kg (309 lbs) | 160 kg (353 lbs) |
| Shipping Weight | 80 kg (176 lbs) | 121 kg (267 lbs) | 140 kg (309 lbs) | 160 kg (353 lbs) |
| Shipping Dimensions, maximum (W x D x H) | 1350 x 750 x 1150 mm 53.1" x 29.5" x 45.3" | 1650 x 750 x 1150 mm 65.0" x 29.5" x 45.3" | 1950 x 750 x 1150 mm 76.8" x 29.5" x 45.3" | 2590 x 1020 x 1100 mm 102.0" x 40.2" x 43.3" |

* Model EBA-___-0 is standard base cabinet without MCB/ELCB
Model EBA-___-8 is with MCB/ELCB protection and only applicable for 230VAC, 50/60Hz units. MCB/ELCB panel is always mounted on the top right hand corner of base cabinet set.

Frontier® RADIOISOTOPE™

Fume Hood • Frontier Radioisotope Fume Hood

Model EFI, Frontier Radioisotope Fume Hood Technical Specifications

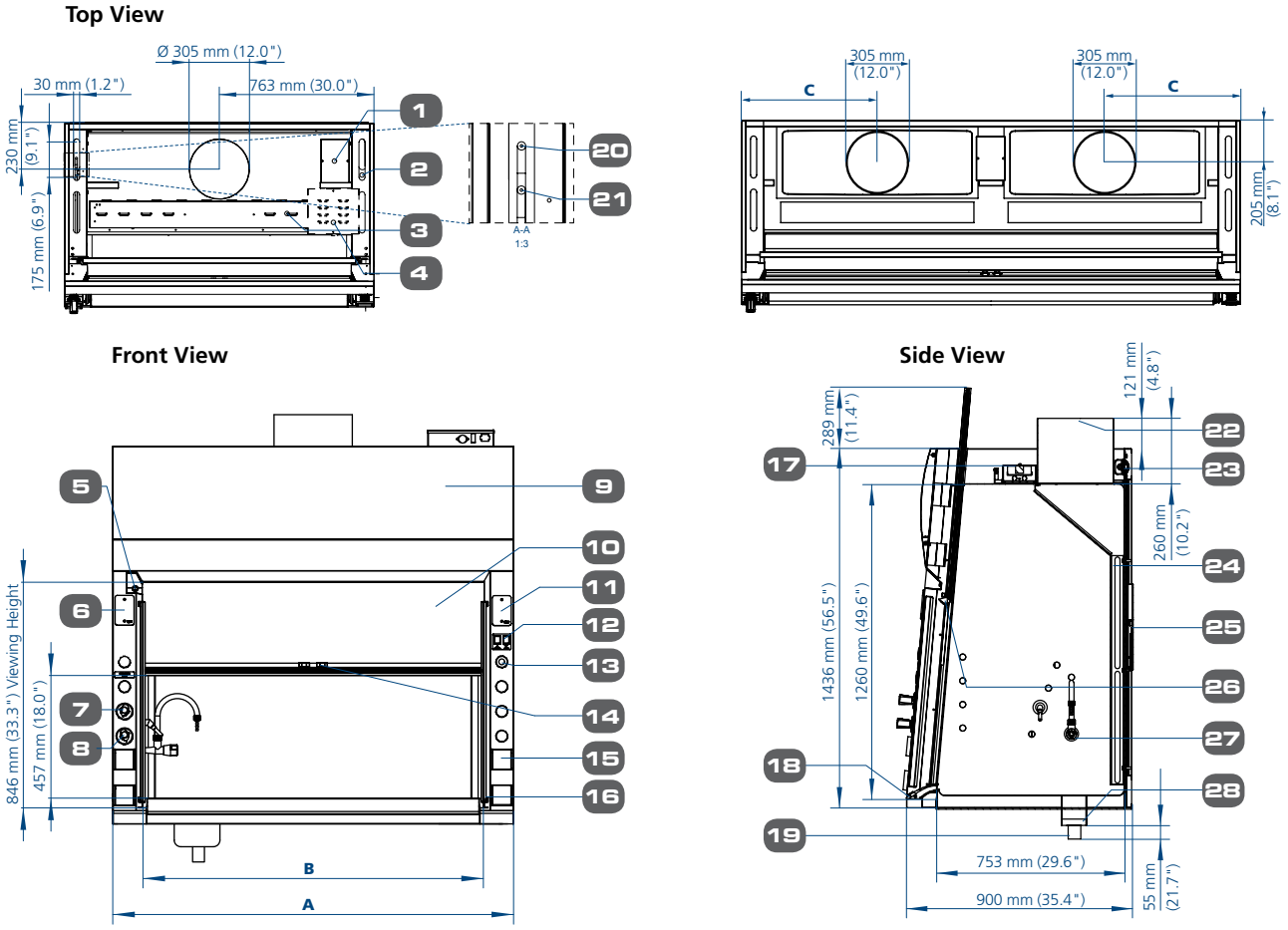

1. Electrical wiring junction box
2. Service fixture pass thru
3. Light box
4. Airflow alarm electronics module (only if optional airflow alarm installed)
5. Sash keylock (lock sash at fully open and fully close)
6. Provision for additional outlets
7. Remote control fixture gas
8. Remote control fixture cold water
9. Curved removable front panel
10. Vertical rising tempered laminated and framed sash glass, creep down above 457 mm (18.0"), replaceable from front of hood
11. Provision for airflow alarm
12. Light and fan switch
13. Provision for additional service
14. Sash stop at operating height, center mounted release
15. Factory installed electrical outlet(s) total 16 Amp specify type and quantity when ordering
16. Acela shaped side vanes
17. Energy-efficient T5 fluorescent light in sealed explosion relief enclosure
18. Flush airfoil, hinged for cleaning, spillage containment 0.4 Litres/ 0.1 Gallons
19. SS 304 cupsink with Ø2" of bushing
20. Cold water inlet, 3/8" copper pipe
21. Gas inlet, 3/8" copper pipe
22. Welded, low noise/pressure drop, stainless steel 304 exhaust collar, also available in SS 316 2B grade
23. Chain drive sash, chain and axle
24. Stainless steel 304 baffle, also available in SS 316 2B grade, diameter 305 mm (12.0")
25. Counter weight, weight field adjustable
26. Aerodynamic full length sash handle
27. Enhanz(TM) service fixture, powder coated finished CW(Cold Water) 1 set, gas(Gas) 1 set, top plumbed additional fixture ordered separately
28. Stainless steel 304, also available in SS 316 2B grade

| Fume Hood Dimensional Data | | | |
|----------------------------|-----------------|-----------------|------------------|
| Model | A | B | C |
| EFI-4UD_ _W_ | 1220 mm (48.0") | 996 mm (39.0") | 610 mm (24.0") |
| EFI-5UD_ _W_ | 1525 mm (60.0") | 1301 mm (51.0") | 762.5 mm (30.0") |
| EFI-6UD_ _W_ | 1830 mm (72.0") | 1606 mm (63.0") | 915 mm (36.0") |
| EFI-8UD_ _W_ | 2440 mm (96.0") | 2216 mm (87.0") | 664 mm (26.0") |

Fume Hood Installation Requirements

- Proper location (refer to Esco recommendations)
- Exhaust system capable of delivering airflow and pressure drop requirements
 - Exhaust ductwork and connection accessories
 - Exhaust blower (or building exhaust system)
 - Contactor (if applicable)
 - Means of adjusting exhaust flow (damper or frequency inverter)
- Sufficient laboratory supply air
- Plumbing and electrical hook-up
- Unless otherwise specified, items and services specified above are not provided by Esco

Model EBA, Technical Specifications of Base Cabinet for Frontier Radioisotope Fume Hood

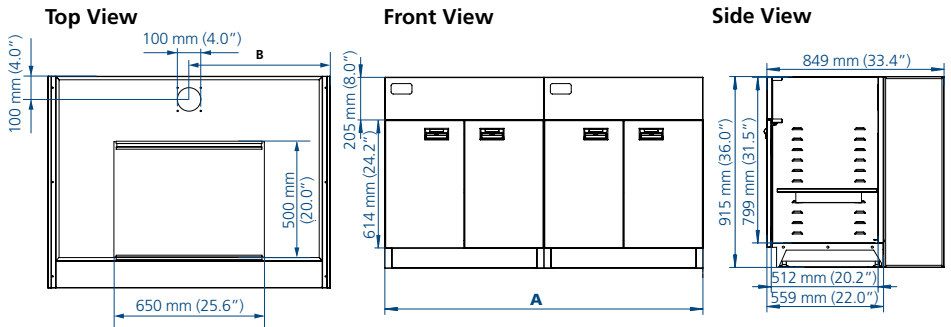

| Model | A | B |
|-------------------------|-----------------|------------------|
| EBA-4UDG-0 / EBA-4UDG-8 | 1220 mm (48.0") | 610 mm (24.0") |
| EBA-5UDG-0 / EBA-5UDG-8 | 1525 mm (60.0") | 381 mm (15.0") |
| EBA-6UDG-0 / EBA-6UDG-8 | 1830 mm (72.0") | 457.5 mm (18.0") |
| EBA-8UDG-0 / EBA-8UDG-8 | 2440 mm (96.0") | 381 mm (15.0") |



- ART Equipment
- Biological Safety Cabinets
- CO₂ Incubators
- Compounding Pharmacy Equipment
- Containment / Pharma Products
- Ductless Fume Hoods
- Lab Animal Research Products
- Laboratory Fume Hoods
- Laboratory Ovens and Incubators
- Laminar Flow Clean Benches
- PCR Cabinets
- PCR Thermal Cyclers
- Powder Weighing Balance Enclosures
- Ultra-low Freezers

Since 1978, Esco has emerged as a leader in the development of controlled environment, laboratory and pharmaceutical equipment solutions. Products sold in more than 100 countries include biological safety cabinets, compounding pharmacy equipment, containment / pharma products, ductless fume hoods, in vitro fertilization workstations, lab animal research products, laboratory fume hoods, laboratory ovens and incubators, laminar flow clean benches and PCR products and instrumentation. With the most extensive product line in the industry, Esco has passed more tests, in more languages, for more certifications, throughout more countries than any biosafety cabinet manufacturer in the world. Esco remains dedicated to delivering innovative solutions for the clinical, life science, research and industrial laboratory community. www.escoglobal.com.

Life Science • Chemical Research • Assisted Reproductive Technology (ART) • Pharmaceutical Equipment • General Equipment



WORLD CLASS. WORLDWIDE.

Esco Technologies, Inc. • 2940 Turnpike Drive, Units 15-16 • Hatboro, PA 19040, USA
 Toll-Free USA and Canada 877-479-3726 • Tel 215-441-9661 • Fax 215-441-9660
us.escoglobal.com • usa@escoglobal.com

Esco Micro Pte. Ltd. • 21 Changi South Street 1 • Singapore 486 777
 Tel +65 6542 0833 • Fax +65 6542 6920 • mail@escoglobal.com
www.escoglobal.com

Esco Global Offices | Beijing, China | Chengdu, China | Kuala Lumpur, Malaysia | Manama, Bahrain | Guangzhou, China | Hanoi, Vietnam | Melaka, Malaysia | Mumbai, India | Philadelphia, PA, USA | Salisbury, UK | Shanghai, China | Seoul, Korea | Delhi, India | Osaka, Japan | Manila, Philippines | Midrand, South Africa | Jakarta, Indonesia | Singapore



9010012_Bumhood_EFH_Schibset_A14_VB1_24-Jan-2013
 Esco can accept no responsibility for possible errors in catalogues, brochures and other printed materials. Esco reserves the right to alter its products and specifications without notice. All trademarks and logos are the property of Esco and its respective companies.